

EDI Technology within the MEDICA[®] Range

The MEDICA EDI 15/30 and 50/100 range of units are equipped with state of the art patented Pulse[®] (EDI) technology. The units provide CLSI clinical laboratory reagent water directly from a potable source. The units combine complimentary technologies to ensure that purified water exceeding the CLRW specification is available when required.

The local water supply is filtered and pretreated through an activated carbon bed to remove chlorine before flowing through reverse osmosis membranes which remove the majority of the ions present in the water. An ion exchange cartridge removes the remaining hardness forming ions from the water before passing it through the Pulse module which removes most of the remaining ions as well as ionisable contaminants such as silica and carbon dioxide.

The purified water is then passed to a reservoir to provide a quantity of water always available for the analyzer. The purified water from the reservoir is recirculated through a series of technologies, including a UV lamp, ion exchange resin and a sub-micron filter, to ensure optimal water quality is maintained and supplied to the analyzer.



Technology Process Flow MEDICA EDI

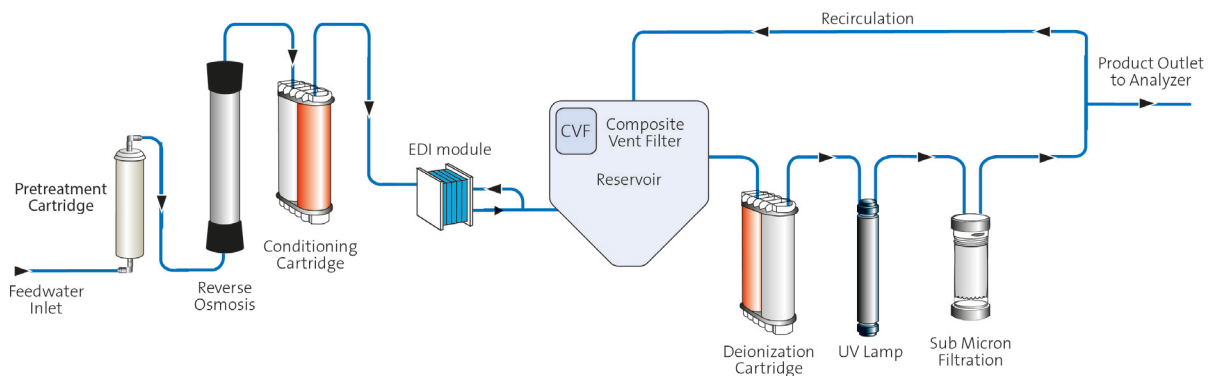

TECHNOLOGY NOTE 39

Electrodeionization (EDI) Technology

Electrodeionization (EDI) is an electrically-driven water purification process that involves the use of Ion Exchange (IX) resins and Ion Permeable Membranes. Water enters the EDI module, where an applied voltage induces ions to move through the resins and across the membranes. These ions are collected into concentrate streams which can then be sent to drain. The deionized product water from an EDI module can then be used directly or undergo further treatment.

The features of ELGA's Pulse module combined with those of the process in the unit give the best results of purifying and maintaining water quality.

Benefits of the Pulse Module

The internal process features anion and cation resin compartments that are widely used to produce ultrapure water. Due to the intrinsic nature of an EDI device, the resins are continuously regenerated by the current and are never exhausted. The benefit is the absence of the adverse effects given by exhaustion of a resin bed, such as silicon, boron or organic breakthrough. Water quality is always maintained.

Changes in pH throughout the module help in reducing the load of bacteria onto the other technologies within the MEDICA EDI and reducing the need for frequent sanitization.

